

CISCO SYSTEMS

ISP Network Design

ISP/IXP Workshops

Cisco ISP Workshops © 2005, Cisco Systems, Inc. All rights reserved. 1

ISP Network Design

- PoP Topologies and Design
- Backbone Design
- ISP Systems Design
- Addressing
- Routing Protocols
- Security
- Out of Band Management
- Operational Considerations

Cisco ISP Workshops © 2005, Cisco Systems, Inc. All rights reserved. 2

CISCO SYSTEMS

Point of Presence Topologies

Cisco ISP Workshops © 2005, Cisco Systems, Inc. All rights reserved. 3

PoP Topologies

- Core routers – high speed trunk connections
- Distribution routers and Access routers – high port density
- Border routers – connections to other providers
- Service routers – hosting and servers
- Some functions might be handled by a single router

Cisco ISP Workshops © 2005, Cisco Systems, Inc. All rights reserved. 4

PoP Design

- Modular Design
- Aggregation Services separated according to connection speed customer service contention ratio security considerations

Cisco ISP Workshops © 2005, Cisco Systems, Inc. All rights reserved. 5

Modular PoP Design

The diagram illustrates a modular PoP design. At the center is a **Network Core** consisting of two interconnected routers. This core is connected to several components:

- ISP Services (DNS, Mail, News, FTP, WWW)**: Connected via a **Web Cache** and **Other ISPs**.
- Hosted Services**: Connected to the core.
- Consumer DIAL Access**: Connected to the core.
- Nx64 customer aggregation layer**: Connected to the core.
- NxT1E1 customer aggregation layer**: Connected to the core.
- Network Operations Centre**: Connected to the core.
- Consumer cable, xDSL and wireless Access**: Connected to the core.

External connections include **Backbone link to another PoP** on both sides. At the bottom, it specifies **Channelised T1/E1 circuits Nx64 leased line circuit delivery** and **Channelised T3/E3 circuits T1/E1 leased line circuit delivery**.

Cisco ISP Workshops © 2005, Cisco Systems, Inc. All rights reserved. 6

Modular Routing Protocol Design

- **Modular IGP implementation**
 - IGP “area” per module
 - aggregation/summarisation where possible into the core
- **Modular iBGP implementation**
 - BGP route reflector cluster per module
 - core routers are route-reflectors
 - clients peer with core only



Point of Presence Design

PoP Modules

- **Low Speed customer connections**
 - PSTN/ISDN dialup
 - low bandwidth needs
 - low revenue, large numbers
- **Medium Speed customer connections**
 - 56/64K to sub-T1/E1 speeds
 - low bandwidth needs
 - medium revenue, medium numbers

PoP Modules

- **High Speed customer connections**
 - E1++ speeds
 - medium bandwidth needs
 - high revenue, low numbers
- **Broad Band customer connections**
 - xDSL, Cable and Wireless
 - high bandwidth needs
 - low revenue, large numbers

PoP Modules

- **PoP Core**
 - Two dedicated routers
 - High Speed interconnect
 - Backbone Links **ONLY**
 - Do not touch them!*
- **Border Network**
 - dedicated border router to other ISPs
 - the ISP's “front” door
 - transparent web caching

PoP Modules

- **ISP Services**
 - DNS (cache, secondary)
 - News, Mail (POP3, Relay)
 - WWW (server, proxy, cache)
- **Hosted Services**
 - Virtual Web, WWW (server, proxy, cache)
 - Information/Content Services
 - Electronic Commerce

PoP Modules

- **Network Operations Centre**
primary and backup locations
network monitoring
statistics and log gathering
direct but secure access
- **Out of Band Management Network**
The ISP Network "Safety Belt"

Cisco ISP
Workshops

© 2005, Cisco Systems, Inc. All rights reserved.

13

Low Speed Access Module

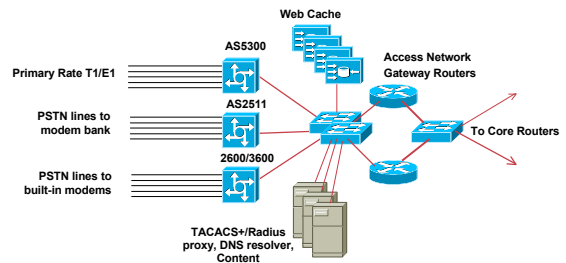

Cisco ISP
Workshops

© 2005, Cisco Systems, Inc. All rights reserved.

14

Medium Speed Access Module

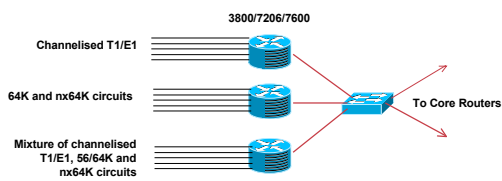

Cisco ISP
Workshops

© 2005, Cisco Systems, Inc. All rights reserved.

15

High Speed Access Module

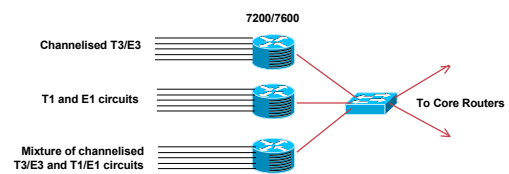

Cisco ISP
Workshops

© 2005, Cisco Systems, Inc. All rights reserved.

16

Broad Band Access Module

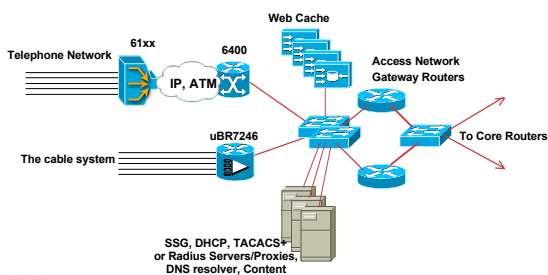

Cisco ISP
Workshops

© 2005, Cisco Systems, Inc. All rights reserved.

17

ISP Services Module

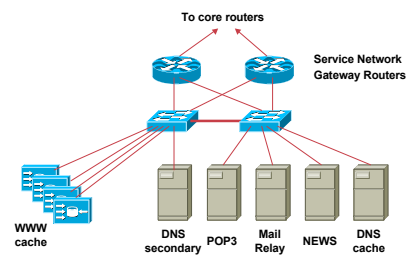

Cisco ISP
Workshops

© 2005, Cisco Systems, Inc. All rights reserved.

18

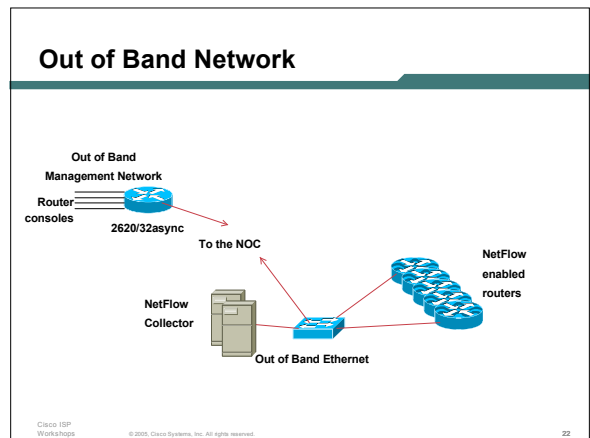
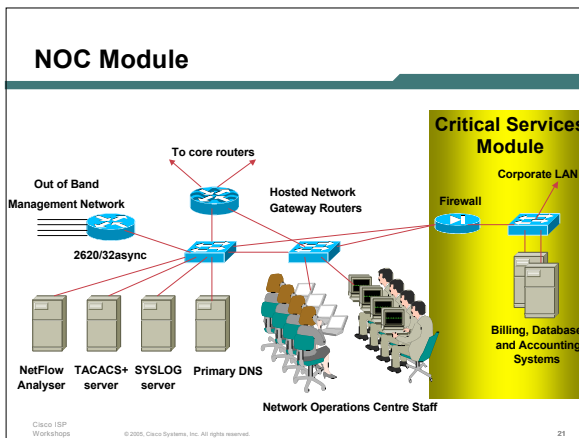
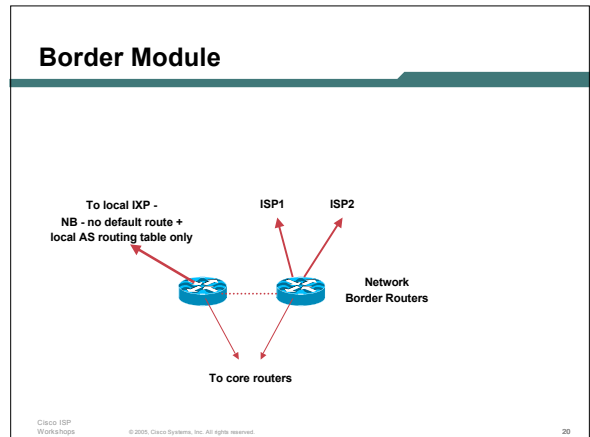
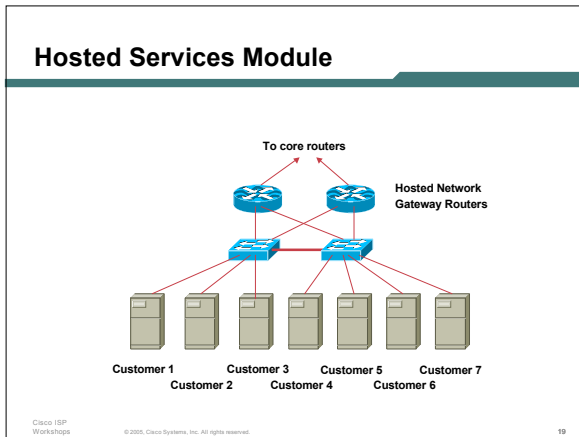

Backbone Network Design

Cisco ISP Workshops © 2005, Cisco Systems, Inc. All rights reserved. 23

- ### Backbone Design
- Routed Backbone
 - Switched Backbone
 - Leased point-to-point circuits
nx64K, T1/E1, T3/E3, OC3, OC12,...
 - ATM/Frame Relay service from telco
T3, OC3, OC12,... delivery
easily upgradeable bandwidth (CIR)
- Cisco ISP Workshops © 2005, Cisco Systems, Inc. All rights reserved. 24

Distributed Network Design

- PoP design “standardised”
operational scalability and simplicity
- ISP essential services distributed around backbone
- NOC and “backup” NOC
- Redundant backbone links

Cisco ISP Workshops © 2005, Cisco Systems, Inc. All rights reserved. 25

Distributed Network Design

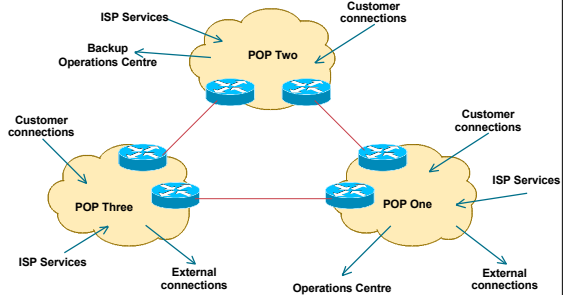

Cisco ISP Workshops © 2005, Cisco Systems, Inc. All rights reserved. 25

Backbone Links

- ATM/Frame Relay
now less popular due to overhead, extra equipment, and shared with other customers of the telco
- Leased Line
more popular with backbone providers
IP over Optics and MPLS coming into the mainstream

Cisco ISP Workshops © 2005, Cisco Systems, Inc. All rights reserved. 27

Long Distance Backbone Links

- Tend to cost more
- Plan for the future (at least two years ahead) but stay in budget
Unplanned “emergency” upgrades can be disruptive without redundancy
- Allow sufficient capacity on alternative paths for failure situations
sufficient can be 20% to 50%

Cisco ISP Workshops © 2005, Cisco Systems, Inc. All rights reserved. 28

Long Distance Links

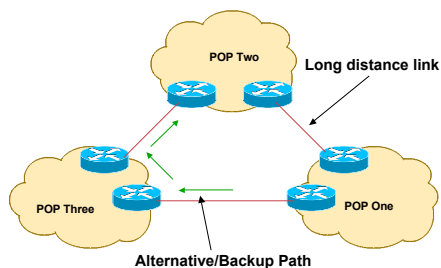

Cisco ISP Workshops © 2005, Cisco Systems, Inc. All rights reserved. 29

Metropolitan Area Backbone Links

- Tend to be cheaper
Circuit concentration
Choose from multiple suppliers
- Think big
More redundancy
Less impact of upgrades
Less impact of failures

Cisco ISP Workshops © 2005, Cisco Systems, Inc. All rights reserved. 30

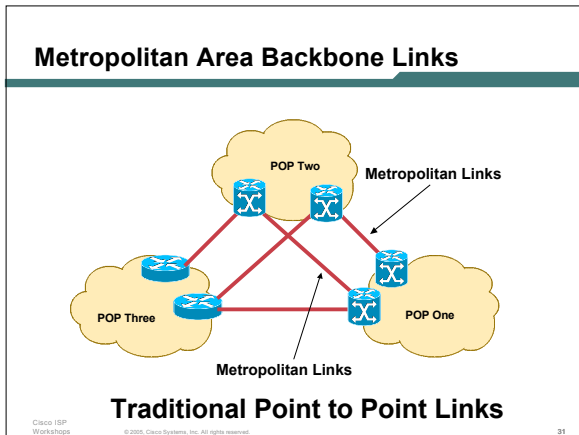

ISP Services

DNS, Mail, News
design and location

Cisco ISP Workshops © 2005, Cisco Systems, Inc. All rights reserved. 32

ISP Services: DNS

- **Domain Name System**
 - Provides name and address resolution
 - Servers need to be differentiated, properly located and specified
 - Primary nameserver
 - Secondary nameserver
 - Caching nameserver – resolver

Cisco ISP Workshops © 2005, Cisco Systems, Inc. All rights reserved. 33

ISP Services: DNS

- **Primary nameserver**
 - Holds ISP zone files
 - forward zone (list of name to address mappings) for all ISP's and any customer zones
 - reverse zone (list of address to name mappings) for all ISP's address space
 - One Unix server, fast I/O, reasonable amount of memory (512Mbytes), reasonable disk
 - Located in secure part of net, e.g. NOC LAN

Cisco ISP Workshops © 2005, Cisco Systems, Inc. All rights reserved. 34

ISP Services: DNS

- **Secondary nameserver**
 - Holds copies of ISP zone files
 - At least two are required, more is better
 - Unix server, fast I/O, reasonable amount of memory (512Mbytes), reasonable disk
 - Should be geographically separate from each other and the primary DNS
 - At different PoPs
 - On a different continent e.g. www.secondary.com
 - At another ISP

Cisco ISP Workshops © 2005, Cisco Systems, Inc. All rights reserved. 35

ISP Services: Secondary DNS Example

- **apnic.net zone**
 - primary DNS in Brisbane
 - secondary DNS around the world

```

$ dig apnic.net ns
;; ANSWER SECTION:
apnic.net.      50m44s IN NS   svc00.apnic.net.
apnic.net.      50m44s IN NS   ns.ripe.net.
apnic.net.      50m44s IN NS   rs.arin.net.
apnic.net.      50m44s IN NS   ns.apnic.net.

;; ADDITIONAL SECTION:
svc00.apnic.net. 1d23h53m25s IN A   202.12.28.131
ns.ripe.net.     1d23h54m46s IN A   193.0.0.193
rs.arin.net.     1d23h53m25s IN A   192.149.252.21
ns.apnic.net.    1d9h29m16s  IN A   203.37.255.97

```

Tokyo
Amsterdam
Washington
Brisbane

Cisco ISP Workshops © 2005, Cisco Systems, Inc. All rights reserved. 36

ISP Services: Secondary DNS Example

- **apnic.net zone**
 - primary DNS in Brisbane (ns.apnic.net)
 - secondary DNS run by APNIC in Tokyo (svc00.apnic.net)
 - zone secondarily by
 - RIPE NCC in Amsterdam
 - ARIN in Washington
 - Geographical and service provider redundancy – this is the perfect example!

ISP Services: DNS

- **Caching nameserver**
 - This is the resolver – it is the DNS cache
 - Your customers use this as resolver, NOT your primary or secondary DNS
 - Provides very fast lookups
 - Does NOT secondary any zones
 - One, or preferably two per PoP (redundancy)
 - Unix server, fast I/O, large amount of memory (512Mbytes+ depending on number of zones)

ISP Services: Caching Nameserver

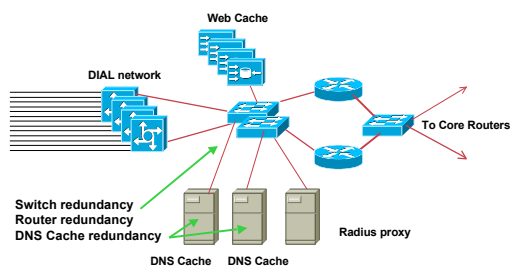

DIAL users automatically given the IP addresses of DNS caches when they dial in

ISP Services: Anycasting the Caching Nameserver

- **One trick of the trade**
 - assign two unique IP addresses to be for the two DNS resolver systems
 - use these two IP addresses in every PoP
 - route the two /32s across your backbone
 - even if the two resolver systems in the local PoP are down, the IGP will ensure that the next nearest resolvers will be reachable
 - Known as IP Anycast



ISP Services: DNS

- **Efficient and resilient design**
 - Primary DNS – keep it secure
 - Secondary DNS – geographical and provider redundancy
 - Don't ever put them on the same LAN, switched or otherwise
 - Don't put them in the same PoP
 - Caching DNS – one or two per PoP
 - reduces DNS traffic across backbone
 - more efficient, spreads the load

ISP Services: DNS

- **Software**
 - Make sure that the BIND distribution on the Unix system is up to date
 - the vendor's distribution is rarely current
 - Pay attention to bug reports, security issues
 - Reboot the DNS cache on a regular (e.g. monthly) basis
 - clears out the cache
 - releases any lost RAM
 - accepted good practice by system administrators

ISP Services: DNS

- **Implementation**

Put all your hosts, point-to-point links and loopbacks into the DNS

- under your ISP's domain name
- use sensible/meaningful names

Put all your hosts, point-to-point links and loopbacks into the REVERSE DNS also

- don't forget about in-addr.arpa – many ISPs do
- some systems demand forward/reverse DNS mapping before allowing access

ISP Services: Mail

- **Must have at least two mail hosts (MX records) for all supported domains**
 - geographical separation helps
- **POP3 server dedicated to that function**
 - DIAL users get mail from here
- **SMTP gateway dedicated to that function**
 - DIAL users send mail via here
- **Mail relay open to CUSTOMERS only!**

ISP Services: Mail Example

- **telstra.net mail (MX records)**
 - primary MX is mako1
 - backup MX is postoffice – two addresses
 - backup MX used if primary unavailable

```
$ dig telstra.net mx

;; ANSWER SECTION:
telstra.net.      1H IN MX  10 postoffice.telstra.net.
telstra.net.      1H IN MX  5 mako1.telstra.net.

;; ADDITIONAL SECTION:
postoffice.telstra.net. 1H IN A  139.130.4.7
postoffice.telstra.net. 1H IN A  203.50.1.76
mako1.telstra.net.    1H IN A  203.50.0.28
```

ISP Services: Mail

- **Software**

Make sure that the MAIL and POP3 distributions on the Unix system are up to date

the vendor's distribution are rarely current

Pay attention to bug reports, security issues, unsolicited junk mail complaints

IMPORTANT: Do NOT allow non-customers to use your mail system as a relay

ISP Services: News

- **News servers provide a Usenet news feed to customers**
- **Distributed design required**
 - Incoming newsfeed to one large server
 - Distributed to feed servers in each PoP
 - Feed servers provide news feed to customers
 - Outgoing news goes to another server
 - Separate reading news system
 - Separate posting news system

ISP Services: News System Placement

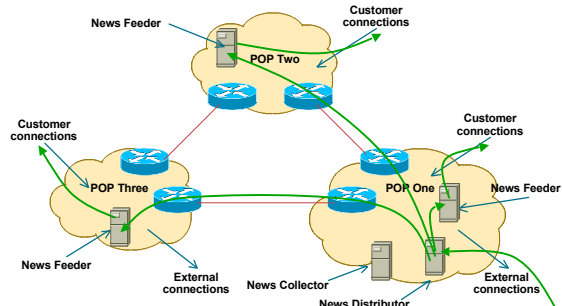

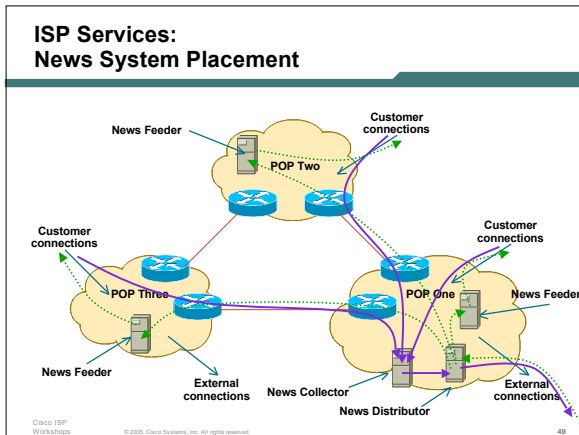

ISP Services: News

- **Software**
 Make sure that the Internet News distribution on the Unix system is up to date
the vendor's distribution is rarely current
 Pay attention to bug reports, security issues, unsolicited junk posting complaints

IMPORTANT: Do NOT allow non-customers to use your news system for posting messages

Cisco ISP Workshops © 2005, Cisco Systems, Inc. All rights reserved. 50

Addressing

Cisco ISP Workshops © 2005, Cisco Systems, Inc. All rights reserved. 51

- ### Where to get IP addresses and AS numbers
- Your upstream ISP
 - Africa
 Afrinic – <http://www.afrinic.net>
 - Asia and the Pacific
 APNIC – <http://www.apnic.net>
 - North America
 ARIN – <http://www.arin.net>
 - Latin America and the Caribbean
 LACNIC – <http://www.lacnic.net>
 - Europe and Middle East
 RIPE NCC – <http://www.ripe.net>
- Cisco ISP Workshops © 2005, Cisco Systems, Inc. All rights reserved. 52

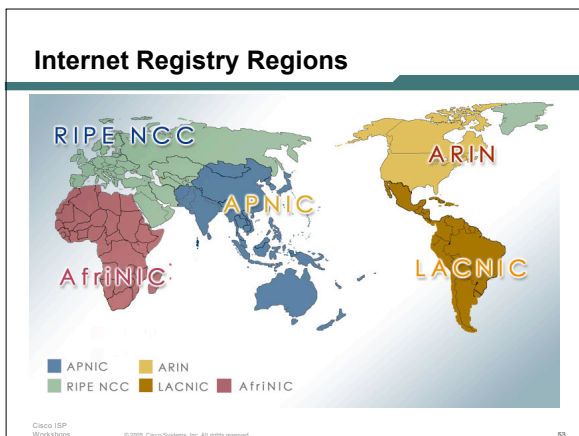

- ### Getting IP address space
- Take part of upstream ISP's PA space
or
 - Become a member of your Regional Internet Registry and get your own allocation
 Require a plan for a year ahead
 General policies are outlined in RFC2050, more specific details are on the individual RIR website
 - **There is plenty of IPv4 address space**
 registries require high quality documentation
- Cisco ISP Workshops © 2005, Cisco Systems, Inc. All rights reserved. 54

Addressing Plans – ISP Infrastructure

- Address block for router loop-back interfaces
- Address block for infrastructure per PoP or whole backbone summarise between sites if it makes sense allocate according to genuine requirements, not historic classful boundaries

Addressing Plans – Customer

- Customers assigned address space according to need
- Should not be reserved or assigned on a per PoP basis
ISP iBGP carries customer nets aggregation not required and usually not desirable

Addressing Plans – ISP Infrastructure

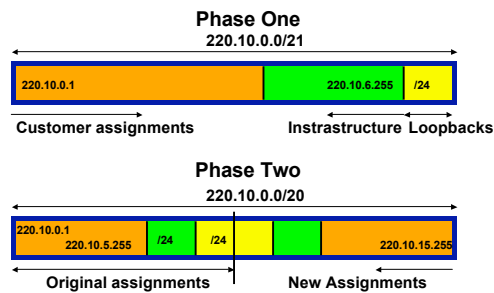

Addressing Plans Planning

- Registries will usually allocate the next block to be contiguous with the first allocation
Minimum allocation is /21
Very likely that subsequent allocation will make this up to a /20
So plan accordingly

Addressing Plans (contd)

- Document infrastructure allocation eases operation, debugging and management
- Document customer allocation contained in iBGP eases operation, debugging and management submit network object to RIR Database



Routing Protocols

Routing Protocols

- **IGP – Interior Gateway Protocol**
carries infrastructure addresses, point-to-point links
examples are OSPF, ISIS, EIGRP...
- **EGP – Exterior Gateway Protocol**
carries customer prefixes and Internet routes
current EGP is BGP version 4
- **No link between IGP and EGP**

Why Do We Need an IGP?

- **ISP backbone scaling**
Hierarchy
Modular infrastructure construction
Limiting scope of failure
Healing of infrastructure faults using dynamic routing with fast convergence

Why Do We Need an EGP?

- **Scaling to large network**
Hierarchy
Limit scope of failure
- **Policy**
Control reachability to prefixes
Merge separate organizations
Connect multiple IGPs

Interior versus Exterior Routing Protocols

- | | |
|--|--|
| <ul style="list-style-type: none"> • Interior
automatic neighbour discovery
generally trust your IGP routers
prefixes go to all IGP routers
binds routers in one AS together | <ul style="list-style-type: none"> • Exterior
specifically configured peers
connecting with outside networks
set administrative boundaries
binds AS's together |
|--|--|

Interior versus Exterior Routing Protocols

- | | |
|---|--|
| <ul style="list-style-type: none"> • Interior
Carries ISP infrastructure addresses only
ISPs aim to keep the IGP small for efficiency and scalability | <ul style="list-style-type: none"> • Exterior
Carries customer prefixes
Carries Internet prefixes
EGPs are independent of ISP network topology |
|---|--|

Hierarchy of Routing Protocols

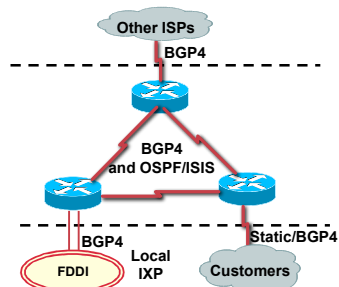

Routing Protocols: Choosing an IGP

- Review the “Introduction to Link State Protocols” presentation
 - i.e. – OSPF and ISIS have very similar properties
- ISP usually chooses between OSPF and ISIS
 - Choose which is appropriate for your operators’ experience
 - In IOS, both OSPF and ISIS have sufficient “nerd knobs” to tweak the IGP’s behaviour

Routing Protocols: IGP Recommendations

- Keep the IGP routing table as small as possible
 - If you can count the routers and the point to point links in the backbone, that total is the number of IGP entries you should see
- IGP details:
 - Should only have router loopbacks, backbone WAN point-to-point link addresses, and network addresses of any LANs having an IGP running on them
 - Strongly recommended to use inter-router authentication
 - Use inter-area summarisation if possible

Routing Protocols: More IGP recommendations

- To fine tune IGP table size more, consider:
 - Use “ip unnumbered” on customer point-to-point links – saves carrying that /30 in IGP
 - (If customer point-to-point /30 is required for monitoring purposes, then put this in iBGP)
 - Use contiguous addresses for backbone WAN links in each area – can then summarise into backbone area
 - Don’t summarise router loopback addresses – as iBGP needs those
 - Use iBGP for carrying anything which does not contribute to the Link State Routing process

Routing Protocols: iBGP Recommendations

- iBGP should carry everything which doesn’t contribute to the IGP routing process
 - Internet routing table
 - Customer assigned addresses
 - Customer point-to-point links
 - DIAL network pools, passive LANs, etc

Routing Protocols: More iBGP Recommendations

- Scalable iBGP features:
 - Use neighbour authentication
 - Use peer-groups to speed update process and for configuration efficiency
 - Use communities for ease of filtering
 - Use route-reflector hierarchy
 - Route reflector pair per PoP (overlaid clusters)
 - Use route flap damping at the network edges



Security

Security

- ISP Infrastructure security
- ISP Network security
- Security is **not optional!**
- ISPs need to:
 - protect themselves
 - help protect their customers from the Internet
 - protect the Internet from their customers
- The following slides are general recommendations
 - do more research on security before deploying any network

Cisco ISP Workshops

© 2005, Cisco Systems, Inc. All rights reserved.

73

ISP Infrastructure Security

- router security
 - usernames, passwords, vty filters, TACACS+
 - Disable telnet on vtys, only use SSH
 - vtv filters should only allow NOC access, no external access
 - See IOS Essentials for the recommended practices for ISPs

Cisco ISP Workshops

© 2005, Cisco Systems, Inc. All rights reserved.

74

ISP Infrastructure Security

- ISP server security
 - usernames, passwords, TCP wrappers, IPTABLES
 - protect **all** servers using routers with strong filters applied
- Hosted services security
 - protect network from hosted servers using routers with strong filters
 - protect hosted servers from Internet using routers with strong filters

Cisco ISP Workshops

© 2005, Cisco Systems, Inc. All rights reserved.

75

ISP Infrastructure Security ISP Server Protection

Access-list examples:

Allow tcp/established to all servers
 ICMP
 DNS 2ary: udp/53 and tcp/53
 POP3: tcp/110
 Mail Relay: tcp/25 and ISP address range only
 News: tcp/119 and ISP address range only
 DNS Cache: udp/53
 Web server: tcp/80

Other necessary filters:

All servers: SSH (tcp/22) from NOC LAN only

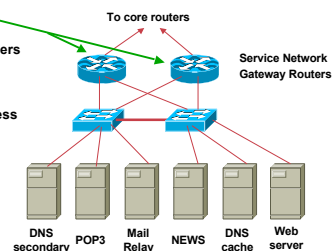

Cisco ISP Workshops

© 2005, Cisco Systems, Inc. All rights reserved.

76

ISP Infrastructure Security Hosted Server Protection

Access-list examples:

Inbound
 Allow tcp/established to all servers
 ICMP
 Web server: tcp/80
 SSH for customer access
 Any other ports for services sold to customers

Outbound
 ICMP
 Allow DNS udp/53 and tcp/53
 Block all access to ISP address range

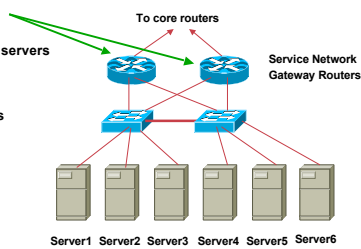

Cisco ISP Workshops

© 2005, Cisco Systems, Inc. All rights reserved.

77

ISP Infrastructure Security

- premises security
 - locks – electronic/card key preferred
 - secure access – 24x7 security arrangements
 - environment control – good aircon
- staff responsibility
 - password policy, strangers, temp staff
 - employee exit procedures
- RFC2196 (Site Security Handbook)
- RFC3871 (Operational Security Requirements for Large ISP Network Infrastructure)

Cisco ISP Workshops

© 2005, Cisco Systems, Inc. All rights reserved.

78

ISP Network Security

- **Denial of Service Attacks**
eg: “smurfing”
see <http://www.denialinfo.com>
- **Effective filtering**
network borders – see Cisco ISP Essentials
customer connections – unicast RPF
network operation centre
ISP corporate network – behind firewall

ISP Network Security Secure external access

- **How to provide staff access from outside**
set up ssh gateway (Unix system with ssh daemon and nothing else configured)
provide ssh client on all staff laptops
ssh available on Unix and Windows
ssh is Secure Shell – encrypted link
- **How not to provide access from outside**
telnet, rsh, rlogin – these are all insecure
open host – insecure, can be compromised

Ingress & Egress Route Filtering

Your customers should not be sending *any* IP packets out to the Internet with a source address other than the address you have allocated to them!



Out of Band Management

Out of Band Management

- **Not optional!**
- **Allows access to network equipment in times of failure**
- **Ensures quality of service to customers**
minimises downtime
minimises repair time
eases diagnostics and debugging

Out of Band Management

- **OoB Example – Access server:**
modem attached to allow NOC dial in
console ports of all network equipment connected to serial ports
LAN and/or WAN link connects to network core, or via separate management link to NOC
- **Full remote control access under all circumstances**

Out of Band Network

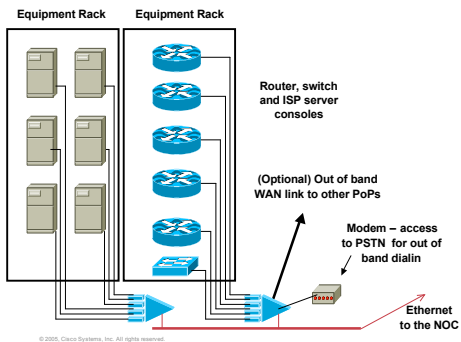

Out of Band Management

- **OoB Example – Statistics gathering:**
 - Routers are NetFlow and syslog enabled
 - Management data is congestion/failure sensitive
 - Ensures management data integrity in case of failure
- **Full remote information under all circumstances**

Cisco ISP Workshops © 2005, Cisco Systems, Inc. All rights reserved. 85



Test Laboratory

Cisco ISP Workshops © 2005, Cisco Systems, Inc. All rights reserved. 87

Test Laboratory

- **Designed to look like a typical PoP**
 - operated like a typical PoP
- **Used to trial new services or new software under realistic conditions**
- **Allows discovery and fixing of potential problems before they are introduced to the network**

Cisco ISP Workshops © 2005, Cisco Systems, Inc. All rights reserved. 88

Test Laboratory

- **Some ISPs dedicate equipment to the lab**
- **Other ISPs “purchase ahead” so that today’s lab equipment becomes tomorrow’s PoP equipment**
- **Other ISPs use lab equipment for “hot spares” in the event of hardware failure**

Cisco ISP Workshops © 2005, Cisco Systems, Inc. All rights reserved. 89

Test Laboratory

- **Can’t afford a test lab?**
 - Set aside one spare router and server to trial new services
 - Never ever try out new hardware, software or services on the live network
- **Every major ISP in the US and Europe has a test lab**
 - It’s a serious consideration

Cisco ISP Workshops © 2005, Cisco Systems, Inc. All rights reserved. 90



Operational Considerations

Cisco ISP Workshops © 2005, Cisco Systems, Inc. All rights reserved. 91

Operational Considerations

Why design the world's best network when you have not thought about what operational good practices should be implemented?

Cisco ISP Workshops © 2005, Cisco Systems, Inc. All rights reserved. 92

Operational Considerations Maintenance

- **Never work on the live network, no matter how trivial the modification may seem**
Establish maintenance periods which your customers are aware of
e.g. Tuesday 4-7am, Thursday 4-7am
- **Never do maintenance on a Friday**
Unless you want to work all weekend cleaning up
- **Never do maintenance on a Monday**
Unless you want to work all weekend preparing

Cisco ISP Workshops © 2005, Cisco Systems, Inc. All rights reserved. 93

Operational Considerations Support

- **Differentiate between customer support and the Network Operations Centre**
Customer support fixes customer problems
NOC deals with and fixes backbone and Internet related problems
- **Network Engineering team is last resort**
they design the next generation network, improve the routing design, implement new services, etc
they do not and should not be doing support!

Cisco ISP Workshops © 2005, Cisco Systems, Inc. All rights reserved. 94

Operational Considerations NOC Communications

- **NOC should know contact details for equivalent NOCs in upstream providers and peers**
- **Or consider joining the INOC-DBA system**
Voice over IP phone system using SIP
Runs over the Internet
www.pch.net/inoc-dba for more information

Cisco ISP Workshops © 2005, Cisco Systems, Inc. All rights reserved. 95



ISP Network Design

Summary

Cisco ISP Workshops © 2005, Cisco Systems, Inc. All rights reserved. 96

ISP Design Summary

- **KEEP IT SIMPLE & STUPID ! (KISS)**
- Simple is elegant is scalable
- Use Redundancy, Security, and Technology to make life easier for yourself
- Above all, ensure quality of service for your customers



ISP Network Design

ISP/IXP Workshops